



[WWW.CEMT.CN](http://WWW.CEMT.CN)

# Proposal For Forklift Battery Making



# Content

## 01

Company Profile

## 02

Layout

- Assembly Layout
- Enveloping Method
- On Site Plate

## 03

Enveloping and Stacking Machine

- Enveloping Structure

## 04

COS

- Work flow Image

## 05

Assembly Line

- Short circuit testing machine
- Lid pacing Machine
- Heat sealing machine
- Trimming machine
- Sealing ring insertion machine
- Leak testing machine
- Laser coding Machine
- Robot unloading system



# PART ONE

## Company Profile

# 1

## CEMT SINCE 1999 24 years

The company has more than 50 numbers of outstanding engineers and experts, represent the advanced technology in battery industry. The company has passed SGS ISO9001: 2008 international quality system certification. CEMT has more than 30 utility patents included 10 invention patents.

添加主标题

The world puts off its mask of vastness to its lover.

添加主标题

The world puts off its mask of vastness to its lover.



请关闭本窗口直接按





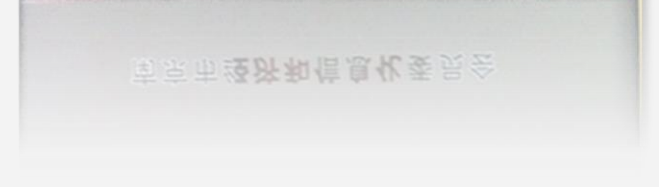
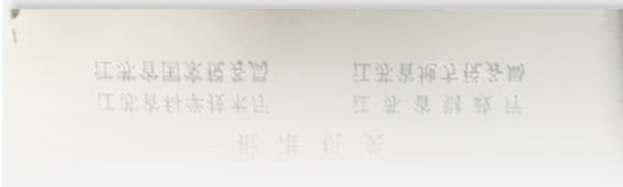
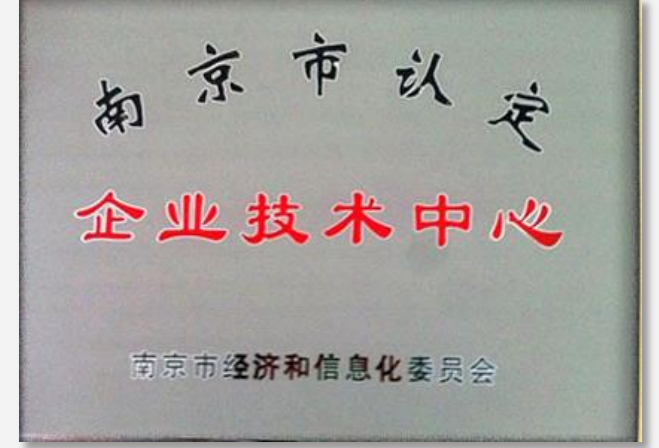

**CEMT totally obtained 79 patents,  
10 invention patents among them.**



# Domestic customer





36 countries, 115 battery plants.

Asia

India



Iran



Bangladesh



Thailand



Indonesia



Vietnam





## Asia

Pakistan



Korea



Kazakhstan

TOO "ZHERSU POWER"

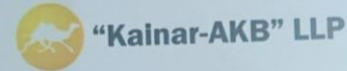

## South America

### Brazil



### Ecuador



### Argentina



### Colombia



### Peru



## Europe

Serbia



Macedonia



Bulgaria



Belorussia



Russia



Ukraine



Poland



Turky



## Africa

Algeria



Egypt



Sudan

Saria Industrial Complex factory

## Latin America

Mexico



# PART TWO

## Proposal

- Layout
- Structure
- On Site
- plate

# 2

# Layout (included the enveloping and stacking machine and COS)

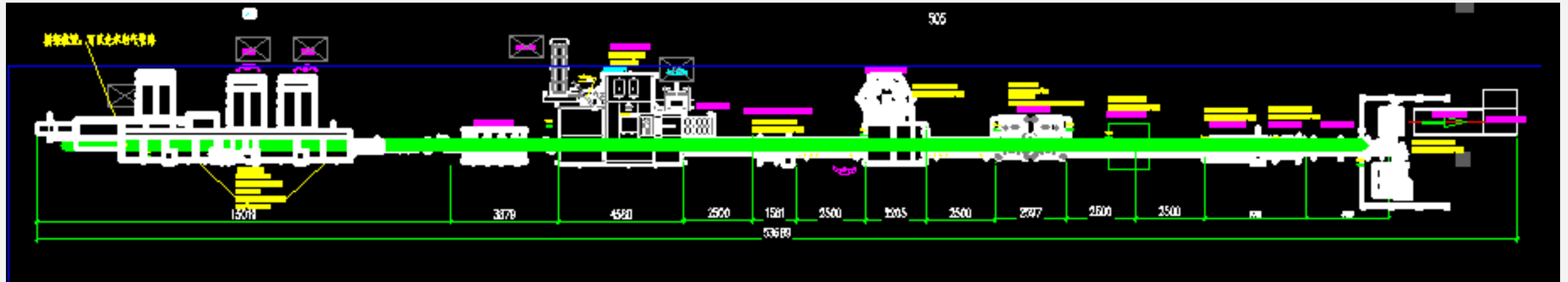





经营理念  
科技创新 服务永  
Technology Innovation, Service Forever

# Plate Picture



**Positive Plate**



**Negative Plate**



**Additional Half  
Thickness  
Negative Plate**

# Plate Dimension-Positive Plate Parameter

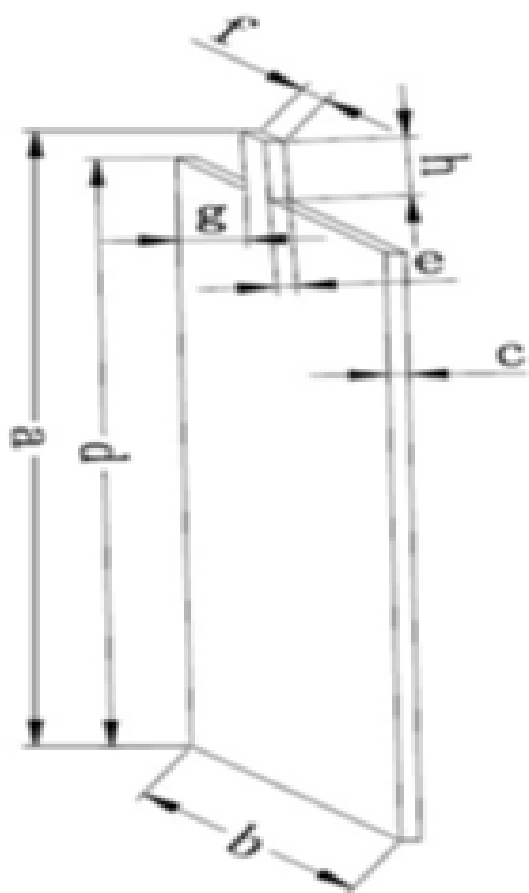

型号	a	b	c	d	e	f	g	h	熟机板重量	备注
	极板总高	极板宽度	极板厚度	极板厚度	极耳厚度	极耳宽度	极耳边距	极耳高度		
	mm	mm	mm	mm	mm	mm	mm	mm	g	g
<b>S19A</b>	153	151	6.9	133	2.8	14	7.5	20	457	S19是A系列极板长度最短的一款极板
<b>S28A</b>	208	151	6.9	188	2.8	14	7.5	20	505	S28是S系列极板长度最长的一款极板

# Plate Dimension-Positive Plate Parameter

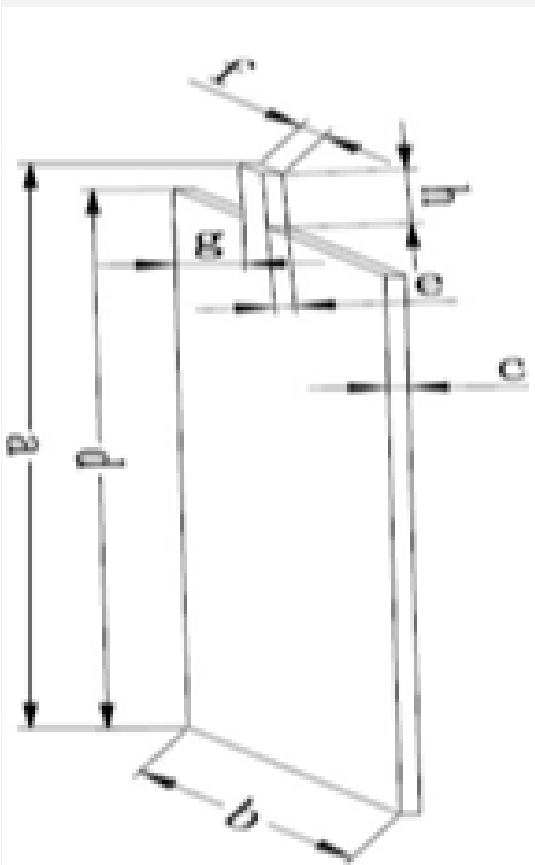

型号	a	b	c	d	e	f	g	h	熟机板重量	备注
	极板总高	极板宽度	极板厚度	极板厚度	极耳厚度	极耳宽度	极耳边距	极耳高度		
	mm	mm	mm	mm	mm	mm	mm	mm		
<b>AB50B</b>	320	141	8.9	291	7	16.5	0	24	1184	AB50是AB系列极板长度最短的一款极板
<b>AB110H</b>	595	141	8.9	566	7	16.5	0	24	2353	AB110H是AB系列极板长度最长的一款极板

# PART THREE

## Enveloping Machine Structure

# 3



# 01 Enveloping Structure

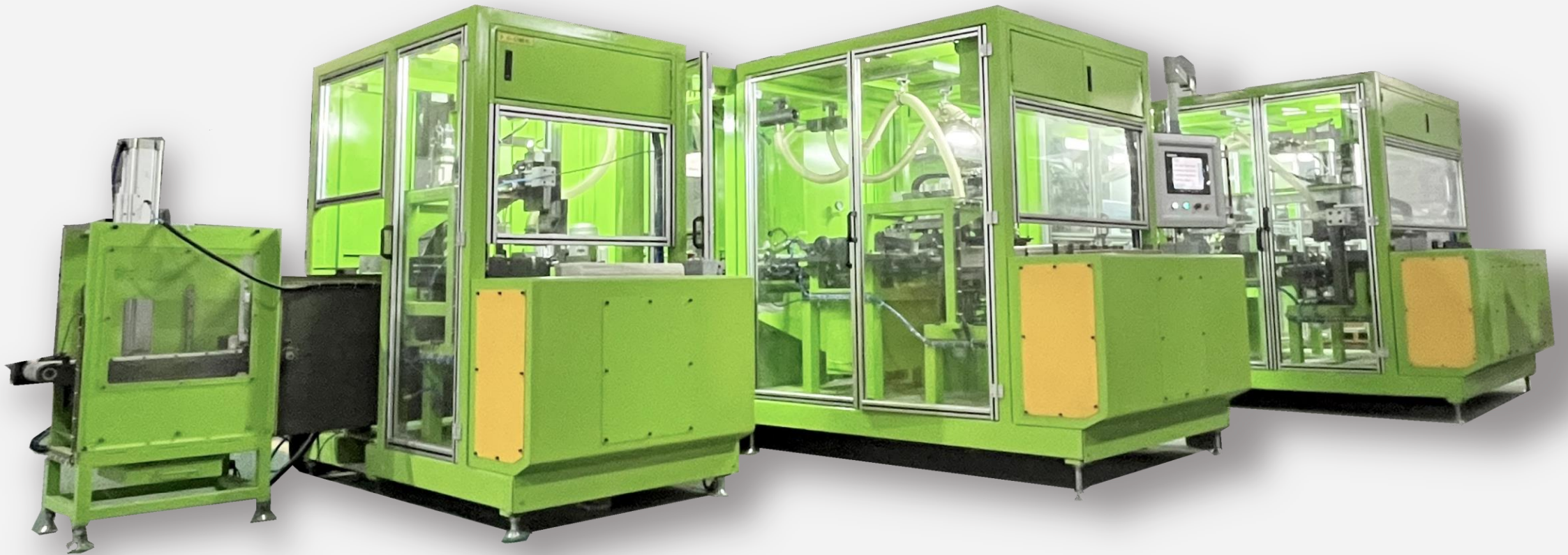

# 01 Enveloping Structure





# 01 Enveloping Structure

**Tubular Positive Plate Loading Position**



**Plastic Separator Loading Position**



**Additional Half thickness Negative Plate Loading Station**



# 01 Enveloping Structure

**Negative Plate Loading**



**Additional Plate Loading**



**Positive Plate Loading**





# 01 Envoloping and Stacking Machine

Seperator Conveying  
Structure

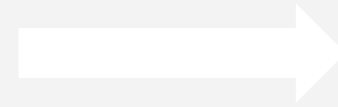
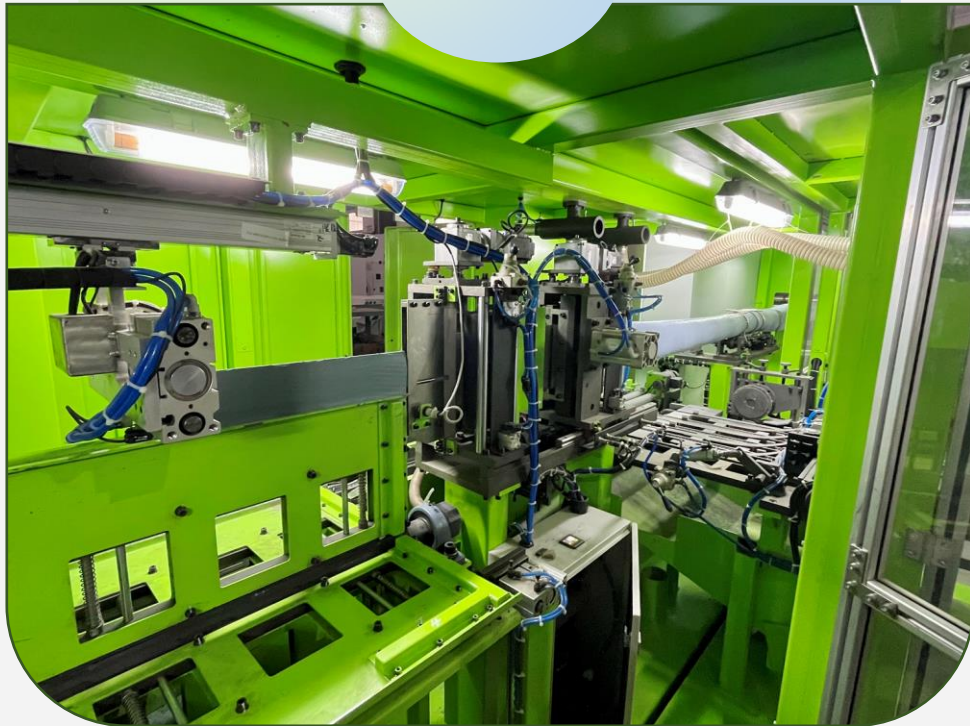

Envoloping Structure





# 01 Enveloping and Stacking machine

Plate Picking up



Plastic Seperator



Plate Groups output

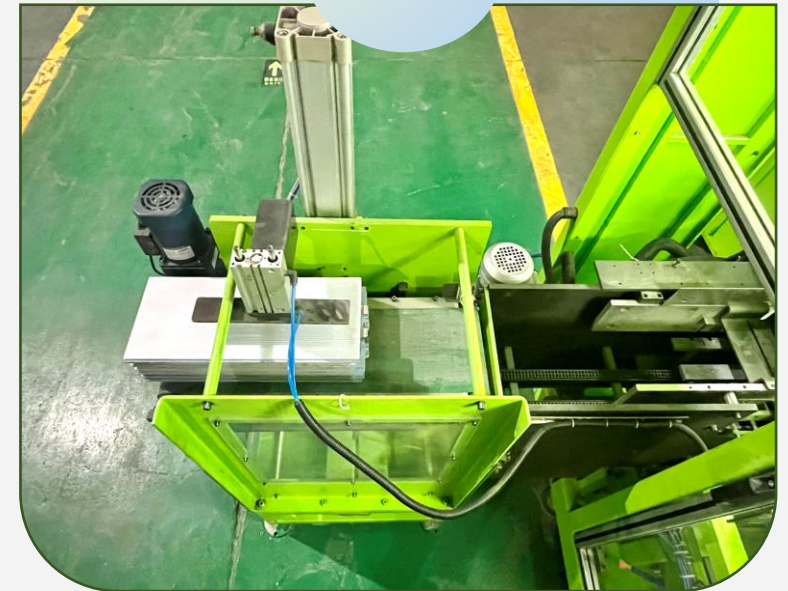

# 01 Sample

Separator sealing

PE Separator

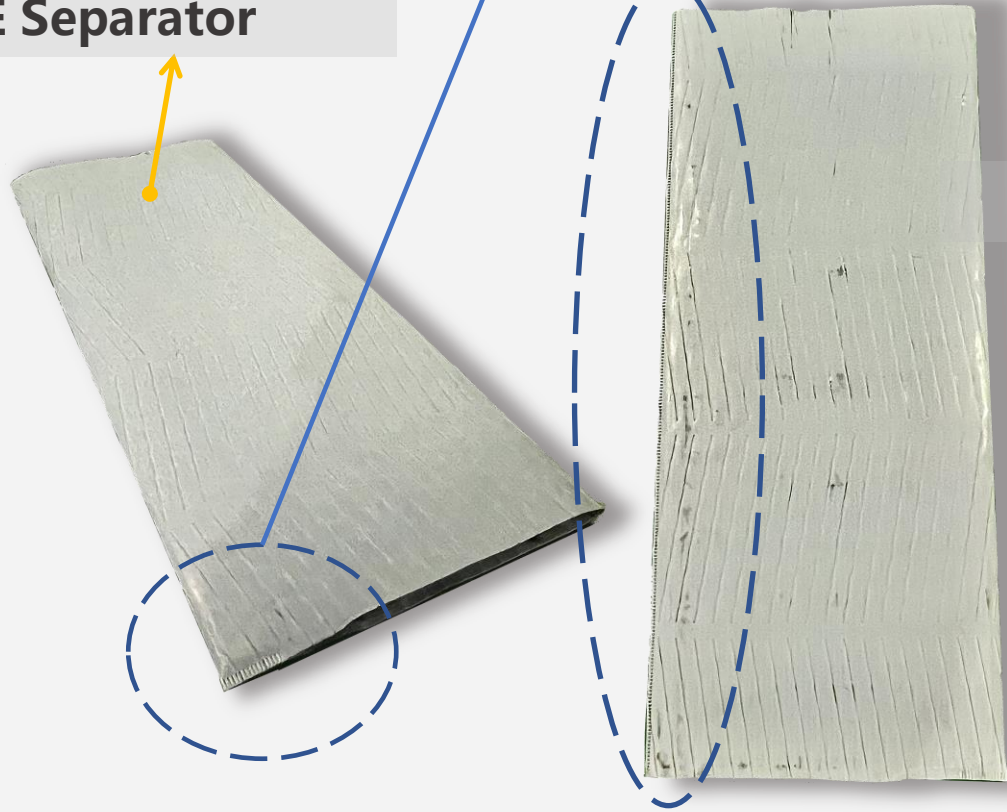
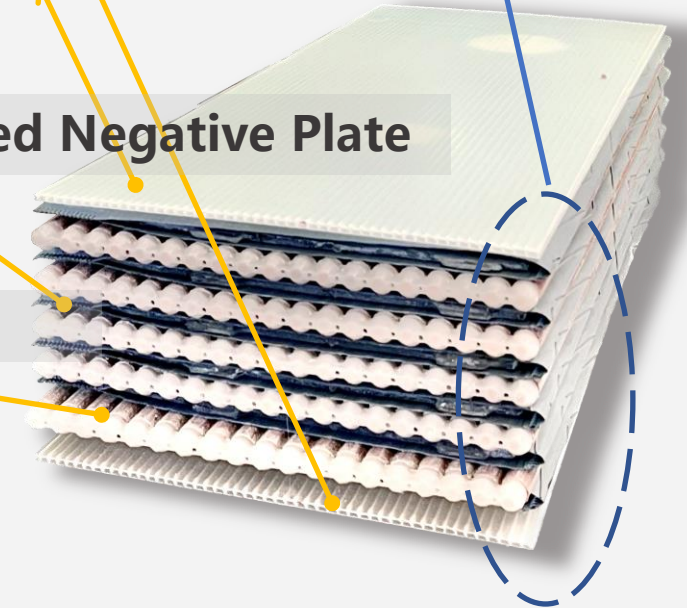

Plate groups

Plastic Separator (glue sealed)

PE Separator Wrapped Negative Plate

Tubular Plate



# PART FOUR

COS

# 4



# COS -Forklift Battery

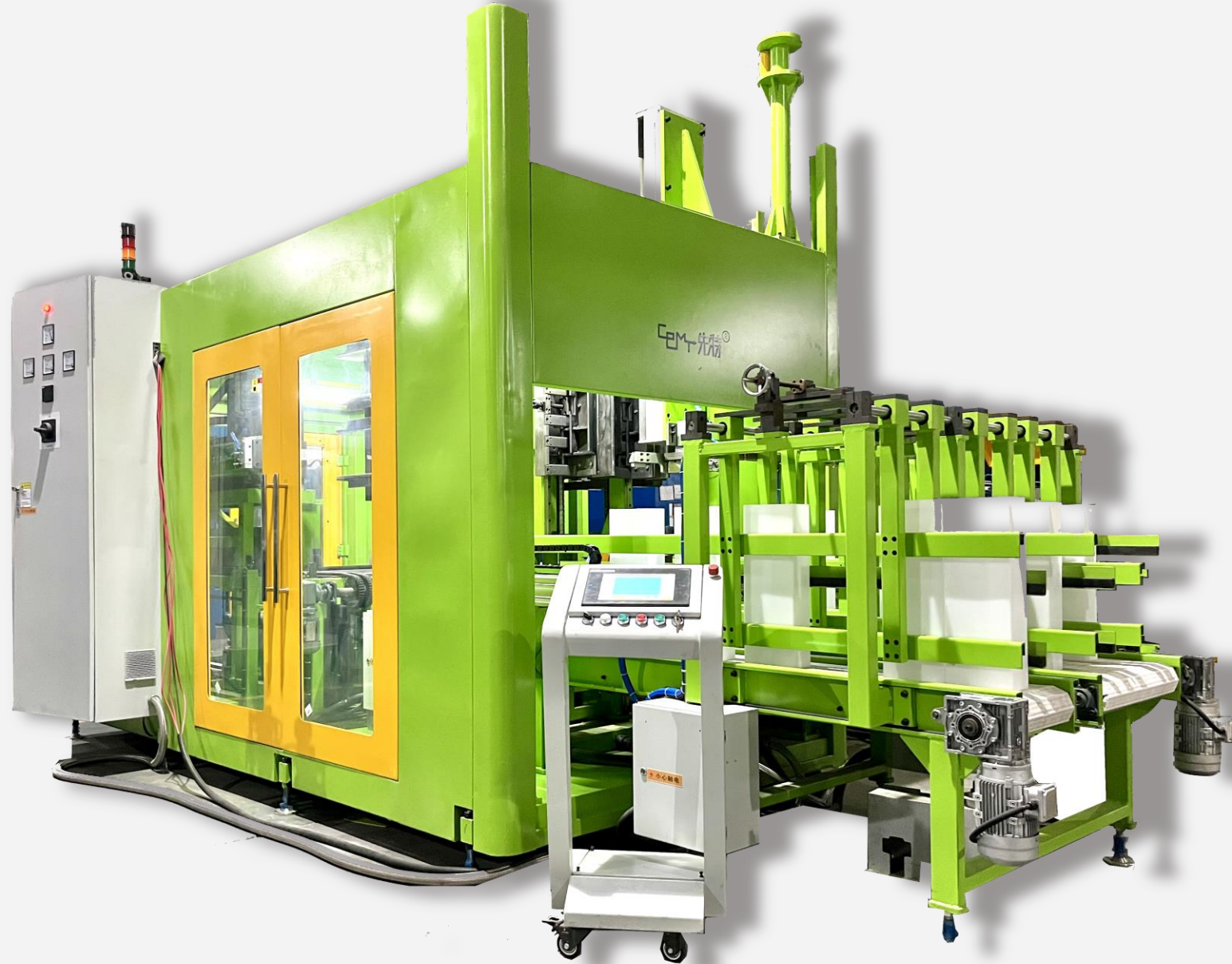

**The first position plate groups loading**

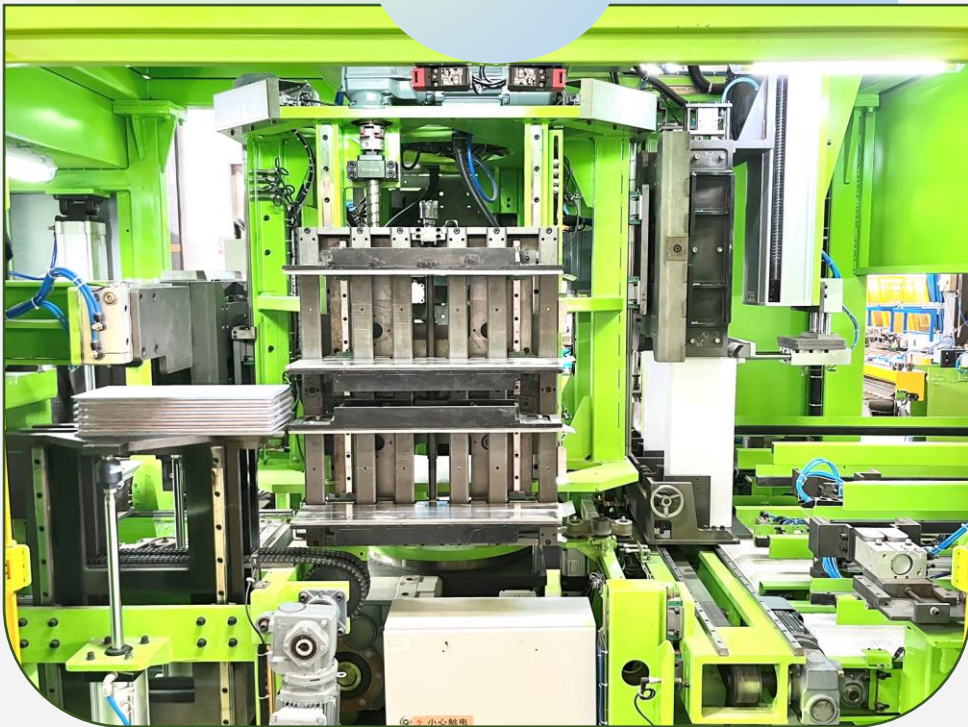

**The second position tinning and fluxing**





## The Third Work Position Casting and Copper Insertion



## The Fourth Position Boxing and Conveying





# COS Samples

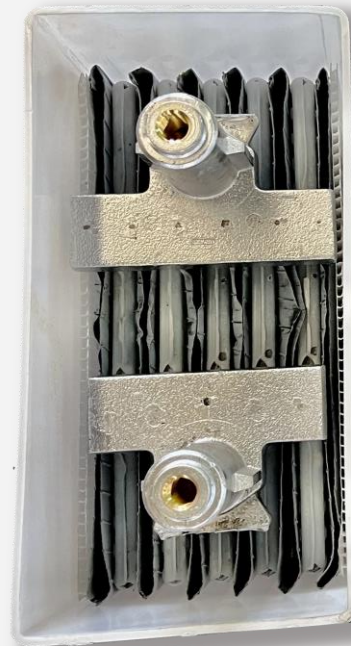

# PART FIVE

## Assembly line

- Short circuit testing machine
- Lid placing machine
- Heat sealing machine
- Trimming machine
- Sealing ring insertion machine
- Leak testing machine
- Laser coding machine
- Unloading robot

# 5

# Short Circuit testing machine

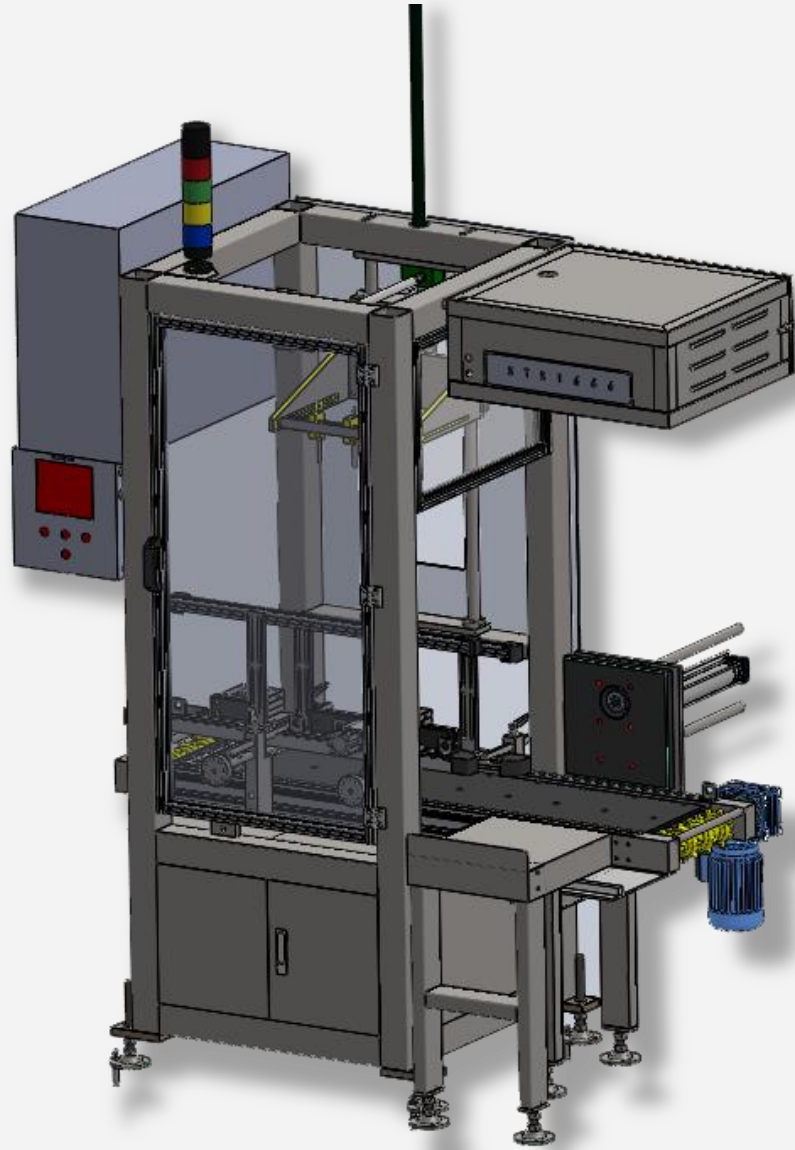

# Lid placing machine-1





# Lid placing machine-2

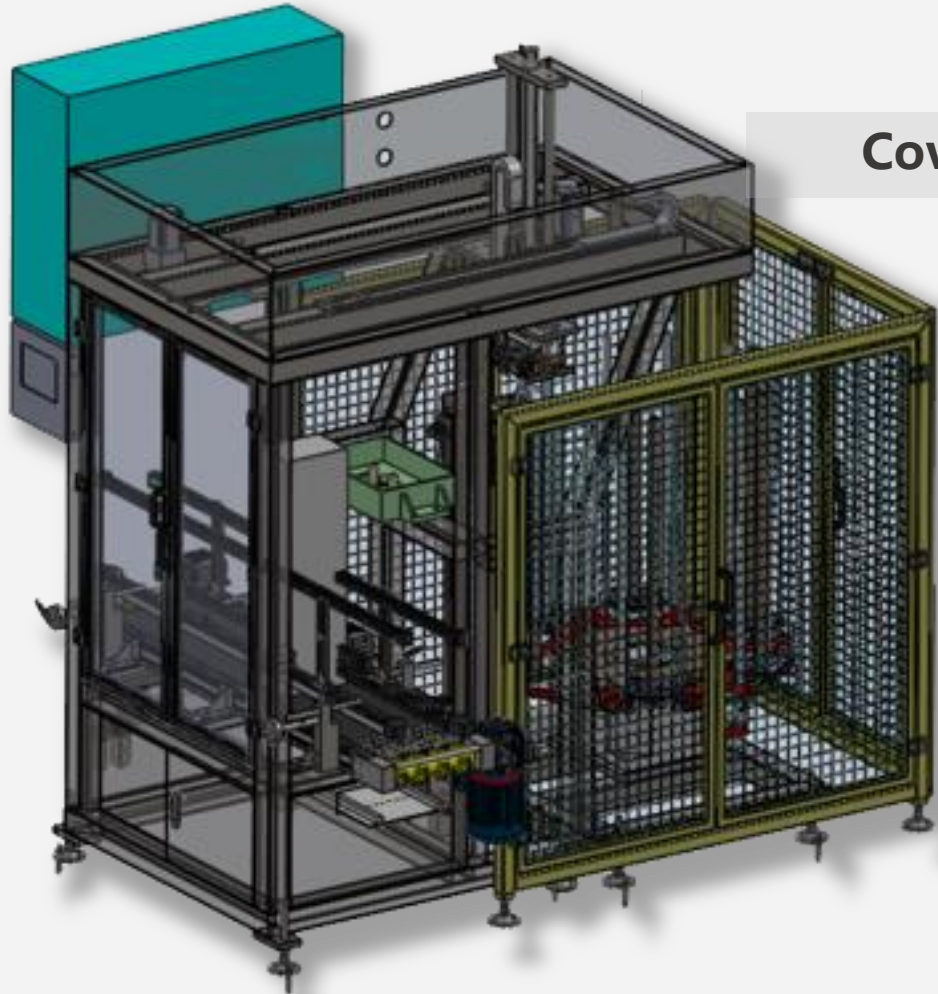

Cover Pick Up Structure

Cover Buffer

Greasing Structure

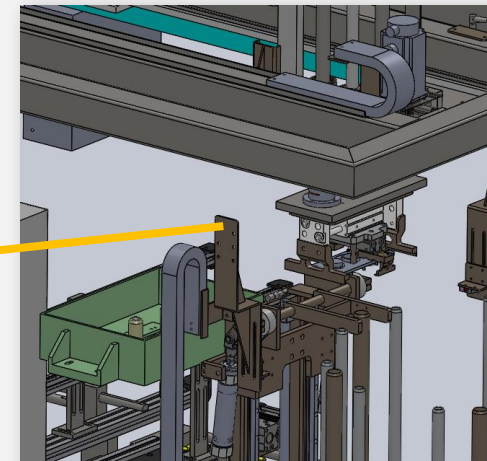
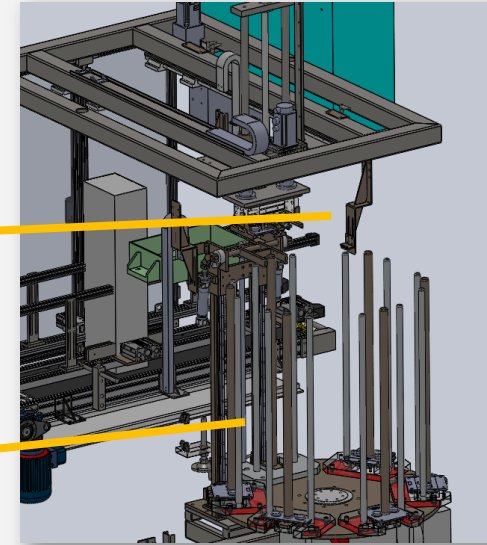

# Heat sealing machine





# Trimming Machine



Cover Picking Up

Rotating Conveyer

Samples After Trimming

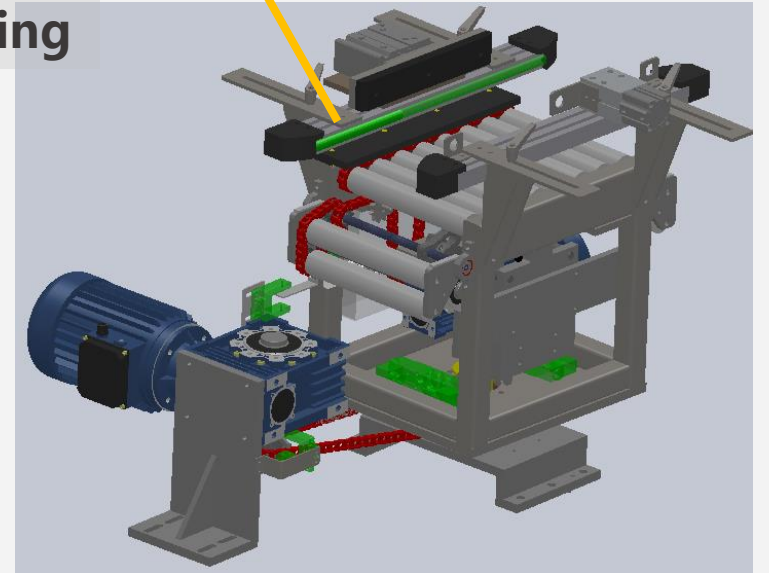
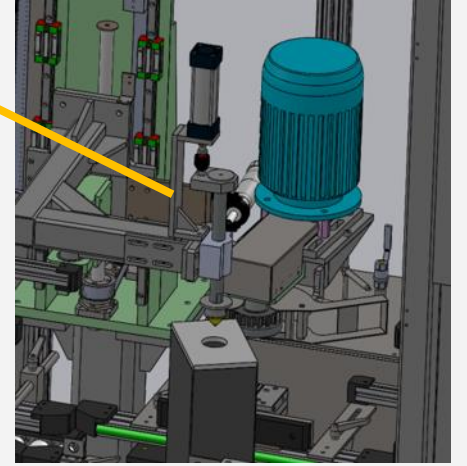

# Sealing Ring Insertion Machine

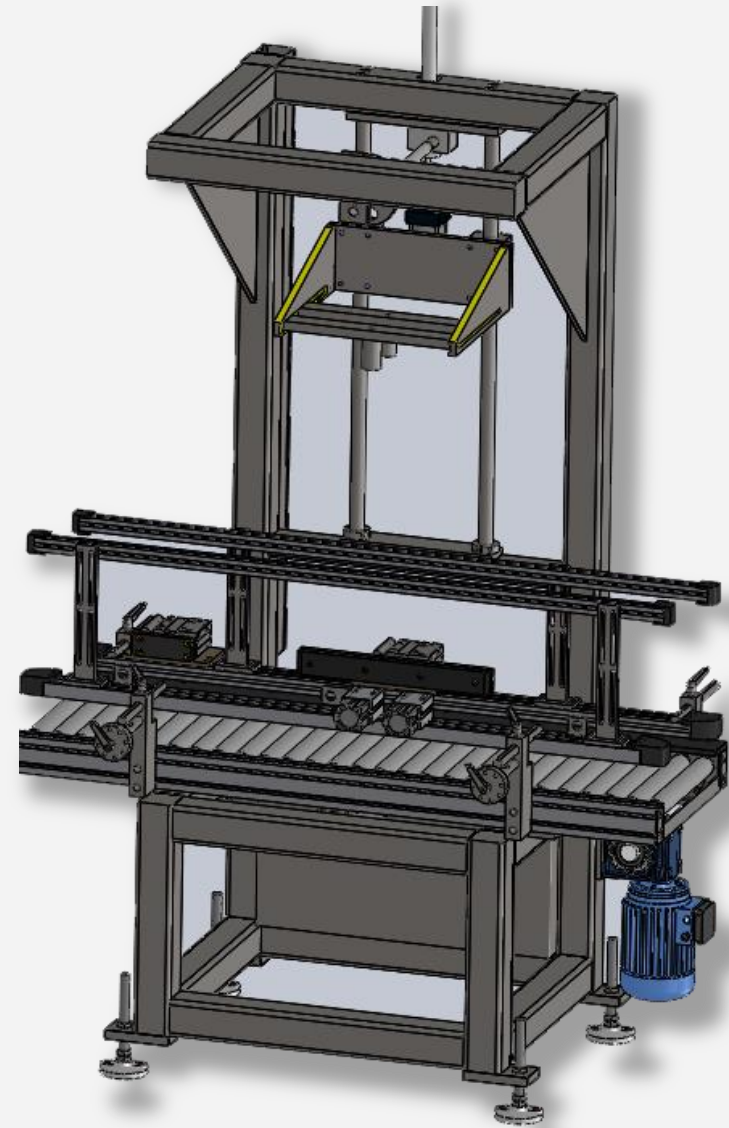

# Leak Testing Machine

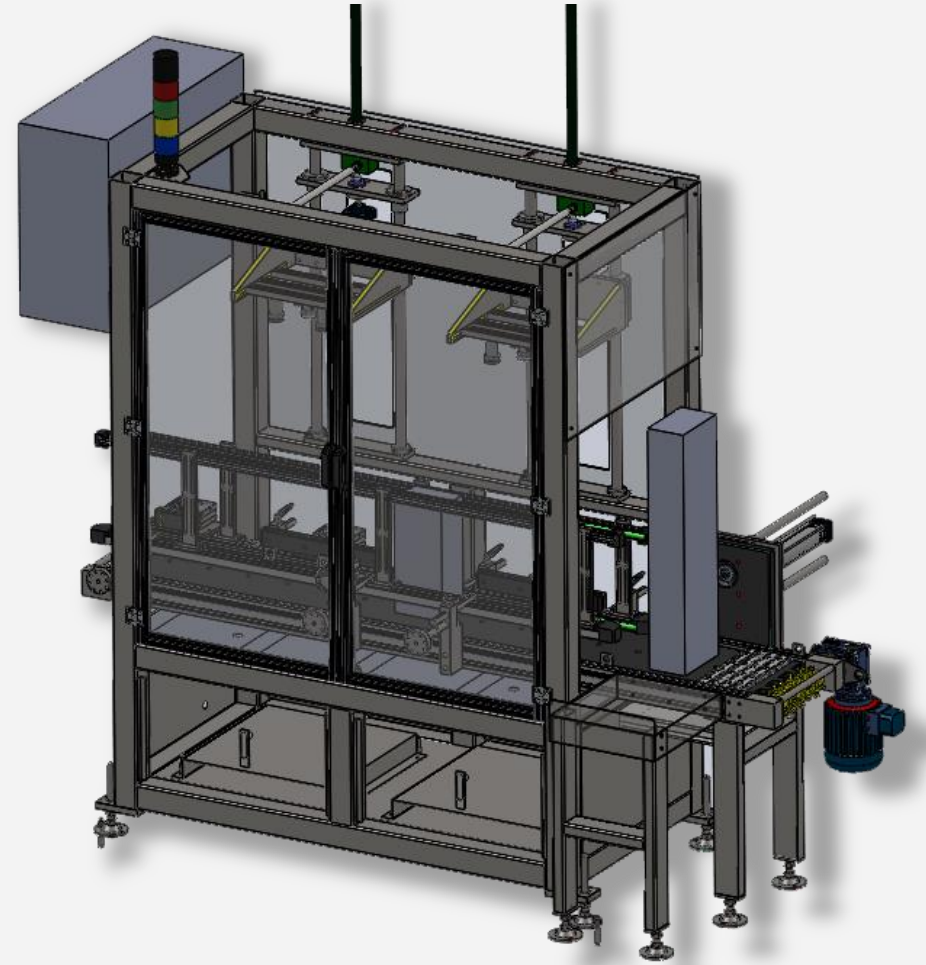



# Laser Coding Machine



Sample

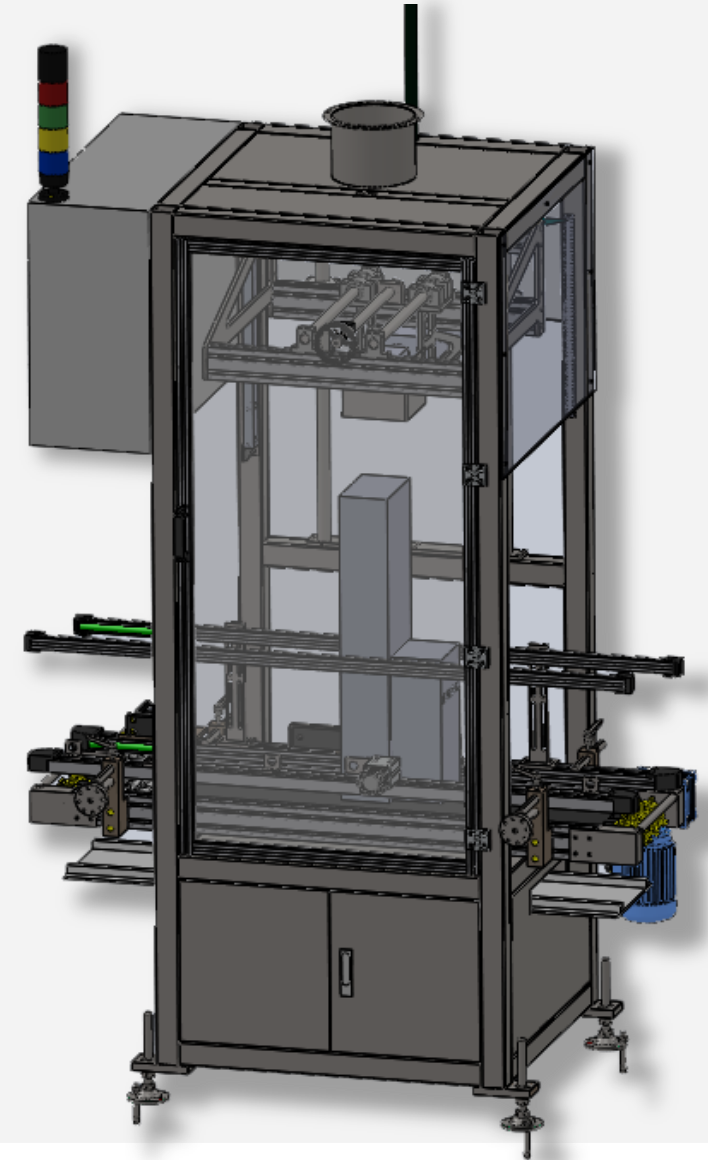

# Unloading Robot System





Jiangsu CEMT Intelligent  
Equipment Co., Ltd.

ADD: NO.115,Xingmin South  
Road,Jiangning,Science Park  
Nanjing,P.R.China

E-mail : [sales@cemt.cn](mailto:sales@cemt.cn)

F-Sales Hotline: +86 25  
87186082 87186061

Aftermarket Line: 400-8899-209

Fax: +86 25 87186081

**THANK YOU!**



CEMT 先特